

INTRODUCTION

Signal flow is an essential concept in modular synthesis: the path taken by audio or control voltages (CVs) may be long or short, branching or linear, intuitive or highly complex.

While the patch programmability of a modular system is its greatest strength, it can also be a weakness: quick experimentation is often hampered by the need to repatch the synthesiser to change the signal flow.

Pivot 2 offers a unique solution: a compact, fully voltage controlled variable signal router. At the turn of a single knob, any signal can be routed through two external modules in series, parallel or reverse series, as well as any combination in between.

Experiment with patching wavefolders before, after or alongside filters, shuffle multiple delay lines, precisely dial in two-stage audio compression or easily control intricate feedback patches.

Looking beyond the basic signal routing application, Pivot 2 will also function as a complementary pair of counter-acting linear voltage controlled amplifiers (VCAs), a voltage controlled crossfader or a voltage controlled panner.

CONTENTS

In the Pivot 2 box, you'll find:

- Product card, stating serial number and production batch.
- 16-to-10-pin Eurorack power cable.
- Mounting hardware: two black M3 x 6 mm hex screws, two black nylon washers and a hex key.
- The Pivot 2 module itself, in a protective cotton bag.

If any of these items are missing, please contact your dealer or support@joranalogue.com.

SIGNAL FLOW

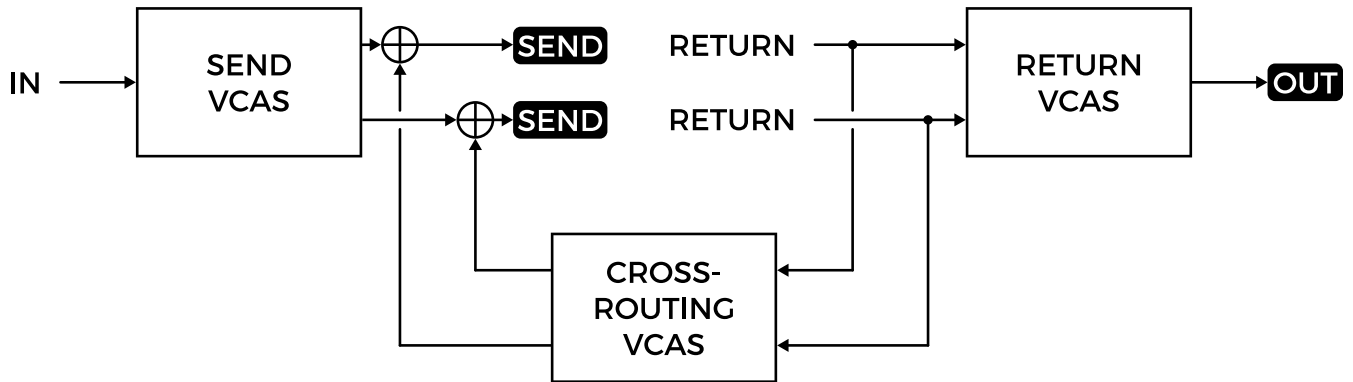

| Input Output → Connection ...▶ Normalised connection Mixer

CONTROLS & CONNECTIONS

1 PIVOT KNOB

The pivot parameter is used to adjust the signal routing throughout the module.

When the knob is set to its minimum setting, the input signal is only sent to the left send output. The signal applied to the left return input is routed to the right send output. Finally, the rightmost return signal is sent to the module's main output. In other words, the send/return pairs are in series, with a left-to-right signal flow.

This order is reversed when the knob is set fully clockwise: the signal is first routed via the right send/return pair, followed by the left pair.

When the knob is centred, the signal is sent through both send/return pairs at 50% amplitude (-6 dB) and mixed together into the main output. This is known as parallel routing.

By adjusting the pivot knob, any setting between series, parallel and reverse series routing may be achieved.

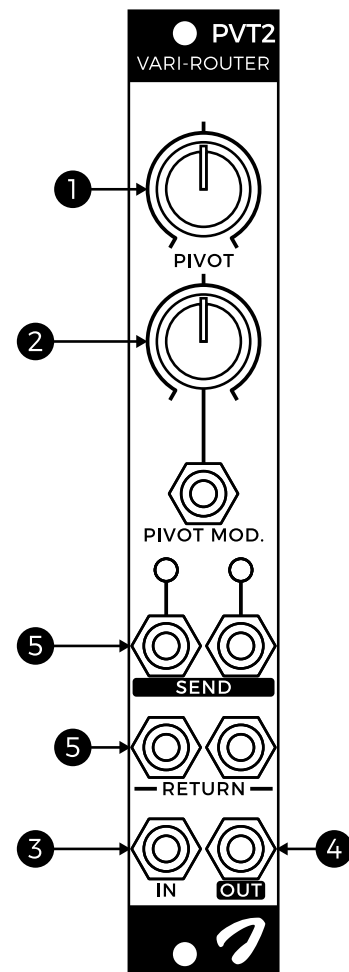

2 PIVOT MODULATION INPUT AND KNOB

The pivot parameter can be modulated through this input, with a total CV range of 10 V. The modulation knob range is bipolar.

The diagrams below show the amount of signal being sent from the main input, as well as returned into the main output, for the full range of the pivot parameter.

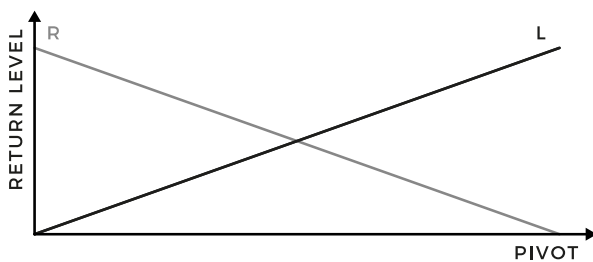
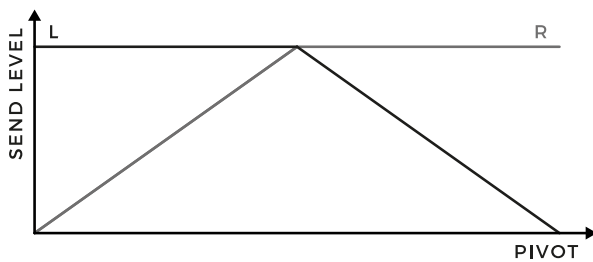

3 MAIN SIGNAL INPUT

This input socket is used to apply the signal which is to be routed via the module's two send/return pairs.

4 MAIN SIGNAL OUTPUT

The result of the send/return routing is available via the main output socket.

5 SEND/RETURN INPUTS AND OUTPUTS

The main input signal is routed via these sockets, as determined by the pivot parameter. The send outputs are typically connected to the inputs of two signal processing modules, for example a filter and a wavefolder. The output of each of these modules is then patched to the matching return input on Pivot 2.

Note that there is no reason to limit yourself to just two external modules: any number of modules may be connected in series in either send/return chain.

PATCH IDEAS

COMPLEMENTARY VCA PAIR

Pivot 2 can be used as a simple linear VCA with complementary outputs: as one rises in amplitude, the other will fall.

Simply patch your signal into the main input. The pivot knob and CV input are used to adjust the VCA's gain. The right send output will yield a standard response, with gain rising as the pivot parameter value rises. Meanwhile, the left send output operates in the opposite direction.

VOLTAGE CONTROLLED CROSSFADER

To use Pivot 2 as a linear crossfader, apply two signals to the return inputs and use the pivot parameter to adjust the balance between them. The resulting signal is available via the main output.

COMPARATOR

Using feedback patching, Pivot 2 may also be used as a comparator, converting analogue signals into gate streams.

Connect the leftmost send output to a multiples module and connect one of its outputs back to Pivot 2's main input. Set the pivot modulation knob to its maximum setting and apply a signal to the CV input socket.

Whenever the signal goes over the threshold value, set by the pivot knob, it will open the send VCA, closing the feedback loop. Small offsets within the circuitry get amplified, saturating the send output at (nearly) +12 V. This gate signal is available from any of the remaining multiples outputs.

SPECIFICATIONS

Module format

Doepfer A-100 'Eurorack' compatible module
3 U, 4 HP, 40 mm deep (inc. power cable)
Milled 2 mm aluminium front panel with non-erasable graphics

Maximum current draw

+12 V: 70 mA
-12 V: 65 mA

Power protection

Reverse polarity (MOSFET)

I/O impedance

All inputs: 100 k Ω
All outputs: 0 Ω (impedance compensated)

Outer dimensions (H x W x D)

128.5 x 20 x 52 mm

Mass

Module: 60 g
Including packaging and accessories: 135 g

SUPPORT

As all Joranalogue Audio Design products, Pivot 2 is designed, manufactured and tested with the highest standards, to provide the performance and reliability music professionals expect.

In case your module isn't functioning as it should, make sure to check your Eurorack power supply and all connections first.

If the problem persists, contact your dealer or send an email to support@joranalogue.com. Please mention your serial number, which can be found on the product card or on the module's rear side.

With compliments to the following fine people,
who helped to make Pivot 2 a reality!

Ben 'DivKid' Wilson Bernhard Rasinger

Björn Jauss Boris Uytterhaegen

Daniel Miller Erwin Van Looveren

Frits Jacobs Hannes d'Hoine

Konstantinos Fioretos Kris Vanderheyden

Lieven Stockx Simon 'BRiES' De Rycke

Yves De Mey

Pivot 2 User Manual
version 2023-06-26

21st Century Analogue Synthesis—Made in Belgium

© 2022—2023

Joranalogue
AUDIO DESIGN

info@joranalogue.com
<https://joranalogue.com/>