

INTRODUCTION

While digital audio processors are often plagued by latency issues, analogue circuits are known for their instant response. But what if you want to delay a signal on purpose, without the use of tape or digital memory? Enter the bucket brigade delay (BBD) line: a series of capacitor 'buckets', which pass the incoming signal along at a high rate in order to delay it.

Delay1 is a fully analogue BBD-based delay module with a multitude of features geared towards modern musical use. An integrated temperature-compensated, high-frequency voltage controlled oscillator (VCO) provides the 'clock' signal necessary to drive the delay line within 1 to 50 ms.

By increasing the drive frequency to over 20 kHz, the typical 'BBD clock whine' problem is solved, while still providing a wide range in delay time. Classic chorus, flanger and echo effects are easily achieved using the dry/wet blend, feedback and damping parameters.

To greatly reduce distortion and noise, Delay1 includes a newly developed control circuit. The improved fidelity is maintained at a multitude of signal levels by an integrated high-performance compander, while preserving signal dynamics.

The module's 'split phase' topology provides two different dry/wet mixes, which may be used to convert mono signals to stereo, for complementary comb filtering and more.

Delay1 also allows you to experiment with Karplus-Strong synthesis, an exciting technique to create string and percussion type sounds. This is made easy by an integrated noise transient generator, driven by the 'pluck' input, and by the clock VCO's 1 volt per octave response.

By re-engineering the classic analogue delay line, Delay1 brings the unique magic of BBDs into the contemporary electronic musician's arsenal.

CONTENTS

In the Delay 1 box, you'll find:

- Product card, stating serial number and production batch.
- 16-to-10-pin Eurorack power cable.
- Mounting hardware: four black M3 x 6 mm hex screws, four black nylon washers and a hex key.
- The Delay 1 module itself, in a protective cotton bag.

If any of these items are missing, please contact your dealer or support@joranalogue.com.

SIGNAL FLOW

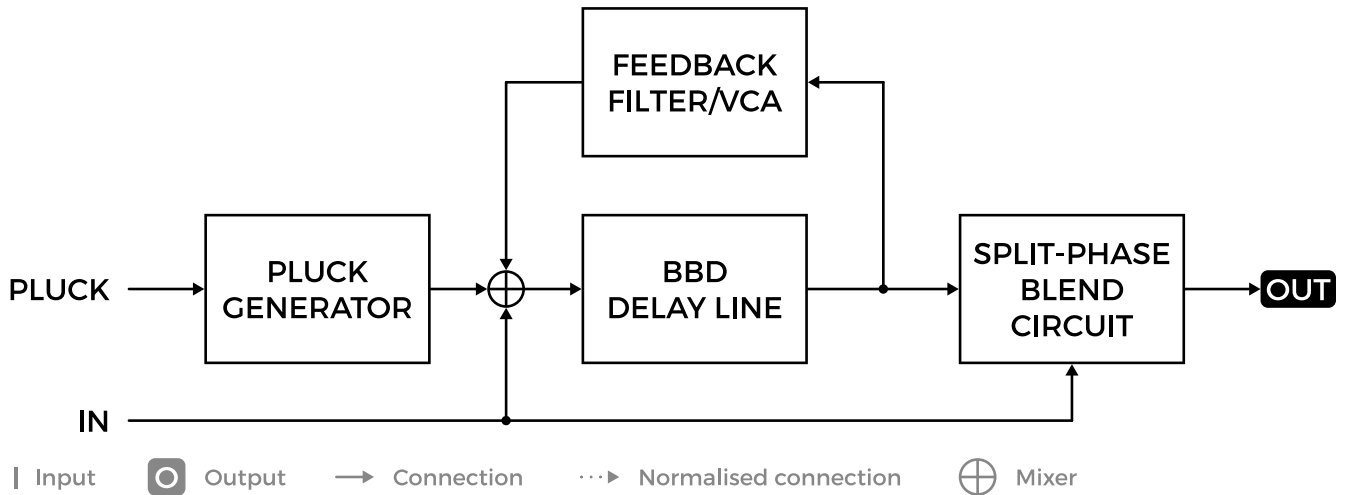

CONTROLS & CONNECTIONS

1 COARSE AND FINE DELAY TIME KNOBS

The length of the delay line is determined by these knobs, with a range of 1 to 50 ms. The most clockwise position corresponds to the shortest delay time. The fine knob's range is 10 % of the coarse knob.

2 VOLT PER OCTAVE TM INPUT

This input is used to modulate the delay time in an exponential fashion, with a standard 1 volt per octave response. This means that each additional volt of CV will halve the delay, making it possible to use Delay 1 as a precise synthesis voice.

3 TIME MODULATION INPUT AND KNOB

This second exponential TM input includes a polariser knob to set the modulation depth, with 0 in the centre, +1 volt per octave maximum and -1 volt per octave minimum.

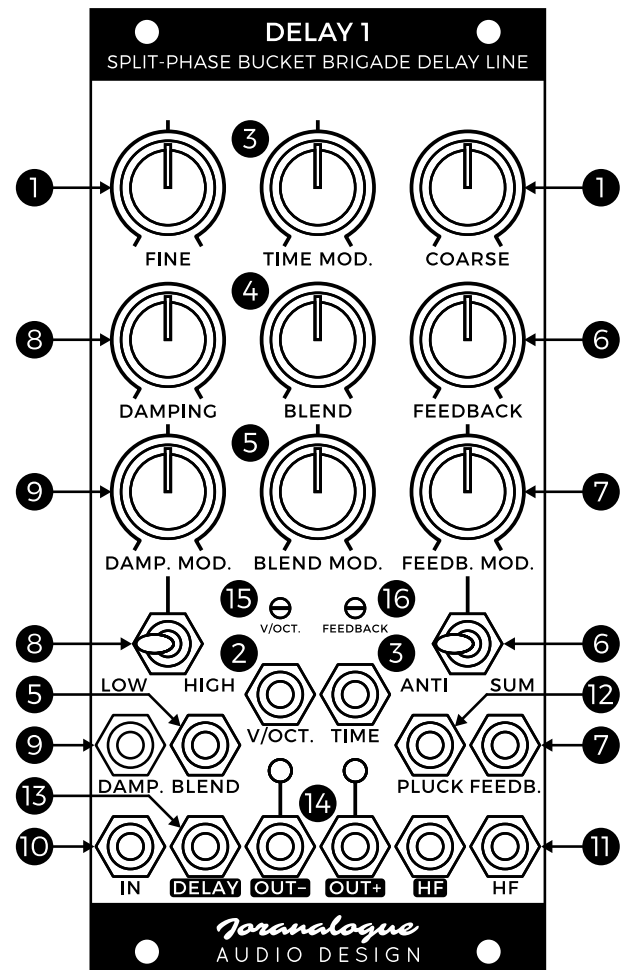

4 BLEND KNOB

The blend knob is used to set the ratio of 'dry' (unprocessed) and 'wet' (delayed) signal, mixed together into the positive and negative outputs. When centred, a 1:1 mix is created, ideal for deep comb filtering or chorus effects. The fully clockwise 100 % wet setting, meanwhile, is more suited for flanger or Karplus-Strong use.

5 BLEND MODULATION INPUT AND KNOB

The blend ratio can be modulated through this input, with +5 V corresponding to 100 % wet. The modulation knob range is bipolar.

6 FEEDBACK KNOB AND POLARITY SWITCH

An integrated feedback loop sends the delayed signal back into the input. At short delay settings, this results in resonances, while echo effects are achieved at longer delay times. This knob sets the amount of feedback, from 0 to (nearly) 100 %.

The feedback can be inverted by setting the polarity switch in its 'anti' setting. This results in different timbres compared to the more typical, in-phase feedback, also known as 'regeneration' (switch setting 'sum').

Note that delay line feedback is unique in that the entire content of the delay 'memory' affects the timbre; hence, repeatedly adjusting the feedback path may result in different sounds being created every time.

Additionally, high amounts of feedback will result in audible saturation of the feedback signal path. This can be used as a deliberate effect, creating additional 'ringing' harmonics.

7 FEEDBACK MODULATION INPUT AND KNOB

The feedback amount can be modulated through this input, with +5 V corresponding to maximum feedback. The modulation knob range is bipolar.

8 DAMPING KNOB AND RESPONSE SWITCH

The feedback path contains an integrated voltage controlled filter—a useful feature to attenuate certain frequencies before they are returned to the delay line's input. This knob changes the corner frequency of the filter, within the range of 22 Hz to 22 kHz.

The filter response may be switched between lowpass and highpass. In both cases, turning the knob further clockwise will increase the amount of (frequency-dependent) attenuation, starting from minimum. In other words, the direction of the frequency sweep is opposite for both settings.

9 DAMPING MODULATION INPUT AND KNOB

The damping can be modulated through this input, which includes a polariser knob to set the modulation depth, with 0 in the centre, approximately +1 volt per octave maximum and approximately -1 volt per octave minimum.

10 SIGNAL INPUT

Connect the audio signal to be processed here.

11 HIGH FREQUENCY INPUT AND OUTPUT

While Delay 1 is normally driven by its own high-frequency (HF) VCO, creating the 'clock' signal required to drive the bucket-brigade delay chip, it is possible to use an external signal to override the internal delay time control.

Simply plug the signal into the HF input. For the best results, this should be a square wave with a 50 % duty cycle and a voltage swing of at least 0 to +5 V.

The recommended frequency range is 20 kHz to 1 MHz. Below this range, longer delay times can be achieved, but the clock will become audible as a high-pitch whine. Frequencies above this range enable extremely short delay times, but with poor audio fidelity. To keep noise and distortion to a minimum, a high-stability clock source is required.

Since the internal HF VCO is disabled once a cable is plugged into the HF input, the coarse and fine knobs will become non-functional, as well as the time modulation CV inputs. In this case, time control is fully driven by the external signal applied to this input.

A buffered copy of the square wave clock signal (either internal or external) is always available from the HF output. This is useful to time-synchronise two or more Delay 1s; for example, to create a stereo pair. This output alternates between +5 V and 0 V.

12 PLUCK INPUT

Delay 1 includes a built-in noise transient generator to create Karplus-Strong sounds. This form of synthesis makes use of delay line feedback, rather than oscillators, to create unique tones. To use this feature, first set the feedback to a moderately high setting with no damping.

A rising edge at the pluck input, reaching above +3 V, will 'strike' the delay line, creating a string-like sound. The frequency, decay time and timbre are set by the delay time, feedback and damping parameters.

13 DELAY OUTPUT

The delayed signal is available via this output socket. It has no mixing functionality, so the blend parameter will not affect it—it is always fully 'wet'.

14 BLEND OUTPUTS

These are the module's main outputs, providing two different mixes of the unprocessed 'dry' signal and the output of the delay line.

The negative output mix consist of the difference between the wet and dry signals, while its positive counterpart provides the sum. The blend parameter determines the mix ratio for both outputs.

This split-phase topology greatly enhances the module's versatility. For example, it means you can use Delay 1 as a mono-to-stereo converter, as this creates the left/right difference necessary for a stereophonic sound field. Additionally, when the module is configured as a comb filter, these outputs will provide opposite filter responses.

15 VOLT PER OCTAVE TRIMMER

This trim potentiometer is used to calibrate the module's pitch tracking. Since it is accessible from the front panel, calibration can be easily performed without removing the module from the system. Each module is individually calibrated during production; do not adjust this trimmer if not needed.

Should you find your Delay 1 to be out of tune, set the range switch to the audio range, the coarse frequency knob to its minimum setting and the fine knob fully clockwise.

Make sure Delay 1 has been powered for at least 20 minutes at a stable ambient temperature. Now connect the high-frequency output to a calibrated digital tuner through a $\div 1024$ frequency divider suitable for signals up to 1 MHz.

During the tuning process, the volt per octave input should be continually switched between 0 V and a precision +4 V source, toggled automatically or by hand. Leave all other inputs unpatched.

Using a dedicated trimming tool or standard 2.5 mm flat screwdriver, adjust the trimmer until the interval between both states is exactly 4 octaves. For example, if 0 V corresponds to a pitch of C1 + 23 cents, +4 V should yield C5 + 23 cents.

16 FEEDBACK TRIMMER

The second trim potentiometer sets the maximum amount of feedback. If calibration is necessary, set the coarse knob to its maximum position and fine fully anticlockwise. Also set damping to minimum, feedback amount to maximum and the switches to high and anti.

Apply a downwards sloping saw wave of frequency 2 Hz and amplitude 10 V_{pp} to the main signal input. Now, adjust the feedback trimpot until the high-frequency ringing of the BBD is just barely audible on the delay output.

PATCH IDEAS

VIBRATO/CHORUS/FLANGER

Vibrato, chorus and flanger form a range of related sound effects that can be easily realised using Delay 1.

For vibrato, apply an audio signal to the input and listen to any of the blend outputs. Set the blend parameter to its maximum setting and disable feedback. Turning the coarse knob continuously will cause the perceived pitch of the signal to be shifted up and down. This effect can be voltage modulated using CV applied to the time modulation input. Only a small amount of modulation is required to obtain a clear vibrato effect.

By reducing the blend parameter to 50 %, the effect changes into chorus. In this case, an equal amount of unchanged 'dry' signal is mixed together with the pitch-shifted 'wet' sound, resulting in a fuller sound.

To turn this into a flanger, turn up the coarse knob to make the delay line shorter and increase the feedback. Resonances now appear, creating the classic flanging sound. Using the damping knob and feedback switches, the feedback path can be adjusted, resulting in a wide range of resonant frequencies being emphasised. Turning the coarse knob to its minimum setting, even spring reverb-like sounds can be realised.

TRIGGER DELAY/BURST GENERATOR

Although Delay 1's signal path is AC-coupled, it can be used to process trigger pulses, as the fast edges contain sufficient high frequency content. This means that the module can be used as a trigger delay, variable between 1 and 50 ms.

Simply apply the trigger signal to the input and use the delay output, adjusting the delay time as required, keeping feedback disabled.

To generate trigger bursts, use the positive blend output instead and set the blend knob to its centre position, mixing together the original trigger and its delayed copy. By turning up the feedback, multiple trigger copies can be created in a single burst.

PERCUSSION SYNTHESISER

In addition to using the dedicated pluck input, it is also possible to simply apply an edge to the regular signal input, in order to synthesise Karplus-Strong-type sounds. The edge can come from an envelope with a fast attack time and moderate release, which using multiples, may then be applied to the time modulation input as well.

This way, a single signal is used to both 'trigger' the delay line as well as time-modulate it. With high feedback at negative polarity ('anti'), moderate low-frequency damping and moderate positive time modulation, the sounds generated are highly reminiscent of bass drums, with a vast selection of timbres accessible through minor adjustments of Delay 1's parameters, as well as the envelope attack and release times.

SPECIFICATIONS

Module format

Doepfer A-100 'Eurorack' compatible module
3 U, 12 HP, 30 mm deep (inc. power cable)
Milled 2 mm aluminium front panel with non-erasable graphics

Maximum current draw

+12 V: 125 mA
-12 V: 95 mA

Power protection

Reverse polarity (MOSFET)

I/O impedance

All inputs: 100 k Ω
Analogue outputs: 0 Ω (impedance comp.)
High-frequency output: 50 Ω

Outer dimensions (H x W x D)

128.5 x 60.6 x 43 mm

Mass

Module: 170 g
Including packaging and accessories: 245 g

SUPPORT

As all Joranalogue Audio Design products, Delay1 is designed, manufactured and tested with the highest standards, to provide the performance and reliability music professionals expect.

In case your module isn't functioning as it should, make sure to check your Eurorack power supply and all connections first.

If the problem persists, contact your dealer or send an email to support@joranalogue.com. Please mention your serial number, which can be found on the product card or on the module's rear side.

With compliments to the following fine people,
who helped to make Delay 1 a reality!

Ben 'DivKid' Wilson Bernhard Rasinger

Björn Jauss Boris Uytterhaegen

Daniel Miller Erwin Van Looveren

Frits Jacobs Hannes d'Hoine

Janus Coorevits Jeroen De Pessemier

Konstantinos Fioretos Kris Vanderheyden

Lieven Stockx Quincas Moreira

Simon 'BRiES' De Rycke Wim Verheyen

Yves De Mey

Delay 1 User Manual
version 2023-06-26

21st Century Analogue Synthesis—Made in Belgium

© 2022–2023

Joranalogue
AUDIO DESIGN

info@joranalogue.com
<https://joranalogue.com/>